

# CARMIX ONE

**CARMIX**  
4x4 mixers & dumpers

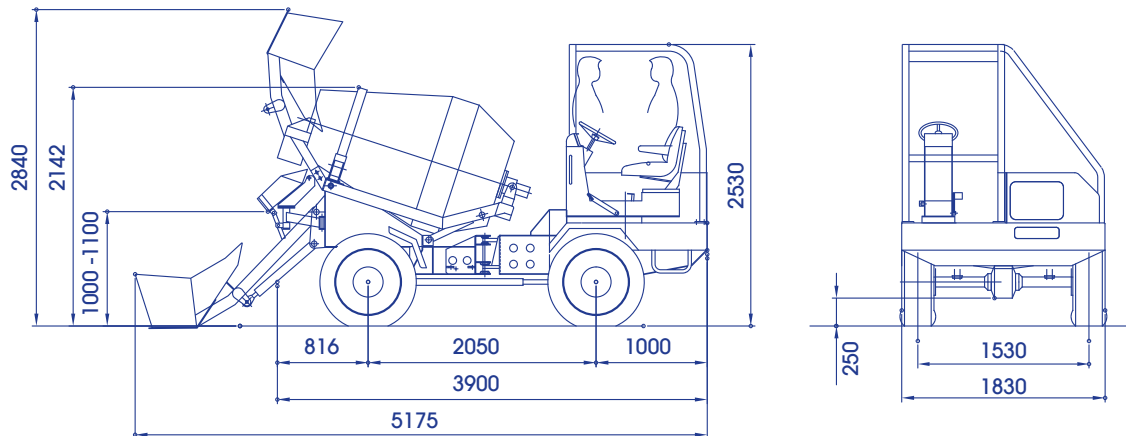

## ACCESSORIES ON DEMAND

Spare wheel

Additional discharging chute (80 cm)

# CARMIX ONE



## MIXING UNIT

Drum capacity 1400 liters. Concrete drum output: 1 m<sup>3</sup>. EN 206-1 IN SLUMP S1 Class, yield not vibrated. Double mixing screws. Cover for emergency unloading. Drum rotation by hydraulic motor and planetary reducers. Mixing and discharging speed independent from r.p.m. of diesel engine. Quick discharge by drum tilting.



## ENGINE

**Perkins Stage III - Tier 3A** 403D-15T Turbo-diesel, 3 watercooled, 3 cylinders. Power KW 29 (39 HP) set at 2.800 rpm. Electric starter.

**Perkins Stage V - Tier 4F** 403J-E17T Turbo-diesel, 4 cylinders, 36 Kw (48 Hp).



## TRANSMISSION

Hydrostatic. A variable outlet pump drives the hydraulic two speed motor connected to the differential through two speed reducers. 4 wheel drive.



## SPEED

Working speed from 0 to 7 km/h, road transfer from 0 to 14 km/h. Electric servo control.



## DRIVING SEAT

Reversible seat with automatic inversion of hydraulic steering circuit. ROPS-FOPS (UNI 11023) Canopy.



## HYDRAULIC SYSTEM

3 circuits. Variable outlet pumps for hydrostatic transmission and drum rotation. Gear pumps for services and steering. Heat exchanger type water/oil-air.



## LOADING SHOVEL

Effective capacity 180 liters.



## CHUTE

Slewing and manually tilting. 2 extra chutes included.



## WATER SYSTEM

Self-contained. Hydraulic driven water pump, water meter, washing outlet.



## GRADIENT

Fully loaded 30%.



## BRAKES

Disc brakes. Twin independent circuits for parking and emergency. Mechanical parking brake acting on rear axle.



## TYRES

Off road industrial type 11,5/80 - 15,3 PR 10.



## STEERING

Hydrostatic and articulated. Radius: internal mm. 2700, external mm. 4600.



## ELECTRIC SYSTEM

12 Volt. 80 Ah battery for electric starter and road lighting. Safety battery cut-off.



## TANKS

Water: 310 liters. Diesel: 35 liters. Hydraulic oil: 25 liters.



## CHASSIS

Articulated steel profile specially engineered for off-road operations.



## WEIGHT

About Kg. 2800. Equally distributed on both axles.



## CATALOGUE

The machine is equipped with Use and Maintenance and Spare Parts Manuals according to CE regulations.

**CARMIX**  
**EVERYWHERE**  
**YOU BUILD**