

# DUMPER D6EVO

**CARMIX**  
4x4 mixers & dumpers

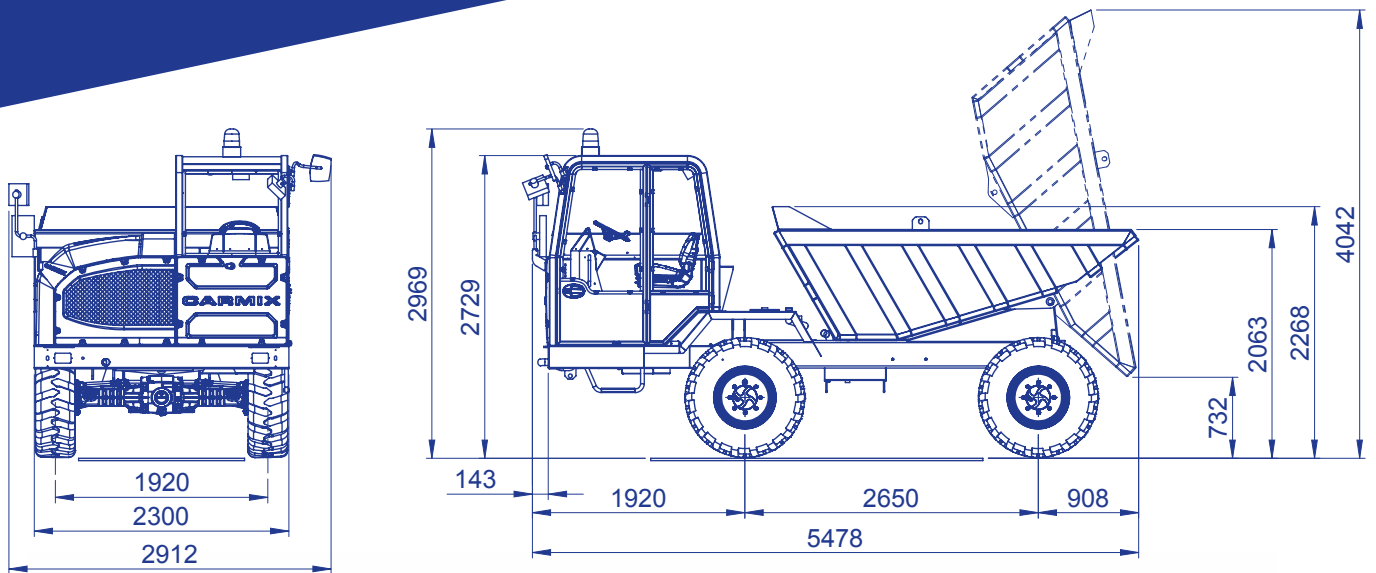

## ACCESSORIES ON DEMAND

Spare wheel

# DUMPER D6EVO



## BUCKET

Struck: 4500 liters. Heaped SAE: 6000 liters.



## PAYLOAD

Kg. 10.000.



## ENGINE

**Perkins Stage III - Tier 3A** 1104D-44TA Turbo-diesel, 4 cylinders, water-cooled. Power 62,5 kW (84 HP) set at 2200 rpm.

**Perkins Stage V - Tier 4F** 904J-E36TA Turbo-diesel, 55,4 Kw (74 Hp).



## TRANSMISSION

Fully hydrostatic Bosch Rexroth with electric inverter. Gear box with mechanic control, two speeds. 4 wheel drive and steering.



## AXLES

Dana Spicer with oil bath disc brakes and planetary reducers.



## SPEED

Working speed from 0 to 9 km/h. Road transfer from 0 to 25 km/h.



## CABIN

Closed cab ROPS FOPS (ISO 20474-1-6) complete with air conditioning and front camera. Reversible diving seat 180° with automatic inversion of hydraulic steering circuit. Rear camera on request.



## SKIP

Heavy duty rock type. Hydraulic tilting with 2 cylinders.



## HYDRAULIC SYSTEM

2 independent circuits, variable outlet pump for hydrostatic transmission and hydraulic pump for services. Heat exchanger water-oil-air/air type.



## BRAKES

Oil bath disc brakes on 4 wheels. Hydraulic parking brake negative on rear axle manually operated.



## TYRES

Off road industrial type 16/70-20 14 PR.



## STEERING

Hydrostatic, "load sensing" type 3 way steering. Radius: internal 2000 mm. external 3700 mm.



## ELECTRIC SYSTEM

12 volt. 120 Ah battery for electric starter and road lighting. Safety battery cut-off.



## GRADIENT

Fully loaded 30%.



## TANKS

Diesel: 115 liters. Hydraulic oil: 80 litri.



## TELAIO

Steel profile specially engineered for off-road operations.



## WEIGHT

Empty: 5.800 kg equally distributed on both axles.



## SAFETY

Machine equipped with checking and block valves for maximum safety of the operator.



## CATALOGUE

The machine is equipped with Use and Maintenance and Spare Parts Manuals according to CE regulations.