

CARMIX 45EVO

CARMIX
4x4 mixers & dumpers

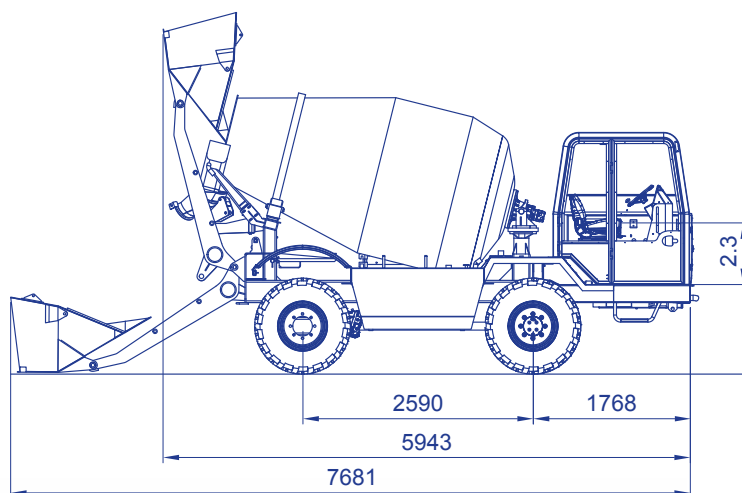
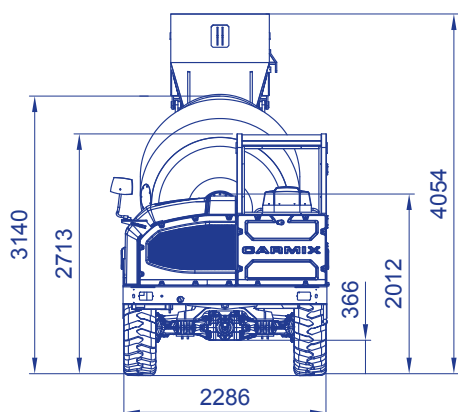

ACCESSOIRES SUR DEMANDE

High-pressure washing pump

Rear camera (front camera standard)

Spare wheel

CARMIX 45EVO



MIXING UNIT

Drum capacity 6050 liters, Concrete drum output: 4,5 m³. Double mixing screws, cover for emergency unloading. Drum rotation by hydraulic motor and planetary reducers. Mixing and discharging speed independent from r.p.m. of diesel engine. Discharging by reversing drum.



ENGINE

Perkins Stage III - Tier 3A 1104D-44TA Turbo-diesel, 4 cylinders, water-cooled. Power 83 kW (111 HP) set at 2200 rpm.

Perkins Stage V - Tier 4F 904J-E36TA Turbo-diesel, 90 Kw (120 Hp).



TRANSMISSION

Hydrostatic Bosch-Rexroth. Heavy duty differential axles with planetary reducers. Front axle swinging and steering. Rear axle fixed.



AXLES

Comer with oil bath disc brakes and planetary reducers.



CHUTE

Slewing and hydraulically tilting. 2 extra chutes included.



WATER SYSTEM

Self-contained. Hydraulic driven water pump, water meter, washing outlet.



GRADIENT

Fully loaded 30%.



BRAKES

Oil bath disc brakes inside differential axles. Twin independent circuits. Negative hydraulic parking brake.



TYRES

Off road industrial type 405/70 - 20 PR18.



STEERING

Hydrostatic. 3 wayS steering. Radius: internal mm 1800 - external mm 3800.



SPEED

Working speed from 0 to 9 Km/h, road transfer from 0 to 25 Km/h. Electric servo control.



CABIN

Closed cab ROPS FOPS (UNI 11023) complete with air conditioning and front camera. Reversible diving seat 180° with automatic inversion of hydraulic steering circuit. Rear camera on request.



HYDRAULIC SYSTEM

3 independent circuits. 2 variable outlet pumps for hydrostatic transmission and drum rotation. 2 pump for services. Inlet and outlet filter. Heat exchanger water/oil-air type.



JOYMIX

All hydraulic functions of shovel controlled by a single - fully servo controlled Joystick.



MYCARMIX

App and on board heavy duty tablet to control and manage mix design, engine diagnostic, geolocation and cloud technology.



LOADING SHOVEL

Effective capacity per load 600 liters, complete with hydraulic opening gate.



ELECTRIC SYSTEM

12 Volt. 120 Ah battery for electric starter and road lighting. Safety battery cut-off.



TANKS

Water: 2x600 liters. Diesel: 130 liters. Hydraulic oil 80 liters.



CHASSIS

Steel profile specially engineered for off-road operations.



WEIGHT

In running order 7.000 Kg, equally distributed on both axles.



SAFETY

Machine equipped with checking and block valves for maximum safety of the operator.



CATALOGUE

The machine is equipped with Use and Maintenance and Spare Parts manuals according to CE regulations.

CARMIX
EVERYWHERE
YOU BUILD