

CARMIX 3500TC

CARMIX
4x4 mixers & dumpers

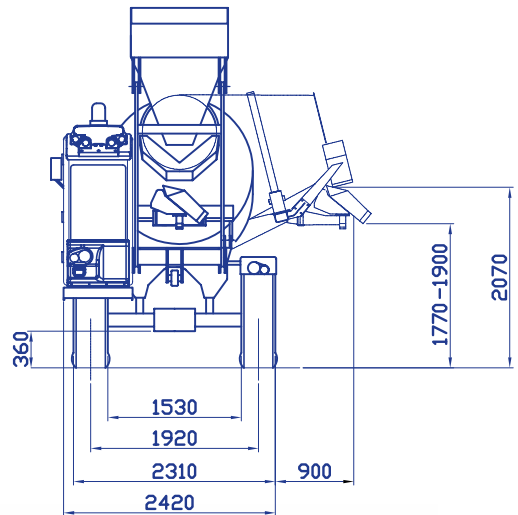
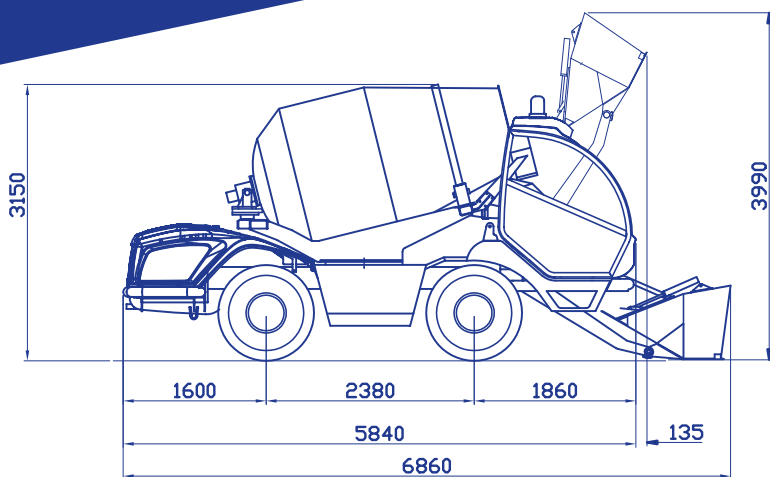

ACCESSORIES ON DEMAND

PROMIX: In-drum probe, easy allows to analyze your concrete

Clima (air conditioning plus heater)

High-pressure washing pump (90 BAR)

Spare wheel

Additional discharging chute (cm 100)

Additive Plant

IPOTWeb modem cloud for ConcreteMate

CARMIX 3500TC



MIXING UNIT

Drum capacity 4.850 liters. Concrete drum output: 3,5 m³. EN 206-1 IN SLUMP S1 Class, yield not vibrated. Double mixing screws, cover for emergency unloading. Drum rotation by hydraulic motor and planetary reducers. Mixing and discharging speed independent from r.p.m. of diesel engine. Discharging by reversing drum. The mixing unit is slewing hydraulically through 270° for high discharge over 2 m on the four sides of the vehicle.



ENGINE

Perkins Stage III - Tier 3A 1104D-44 TA Turbo-diesel, watercooled, 4 cylinders. Rated power KW 83 (111 HP) set at 2.300 rpm. Engine mounted transversal on the rear.
Perkins Stage V - Tier 4F 904J-E36TA Turbo-diesel, 90 Kw (120 Hp).



TRANSMISSION

Hydrostatic Bosch Rexroth. Pump and motor are connected to the differentials through a 2 speed reducer (working and transfer). 4 wheel drive and steering.



AXLES

Dana Spicer with oil bath disc brakes and planetary reducers.



SPEED

Working speed from 0 to 9 km/h, road transfer from 0 to 25 km/h. Electric servo control.



CABIN

Comfort, safe and visibility matching edge design. ROPS-FOPS (UNI 11023) complete with closing door and rear view camera. Clima, air conditioning heater available upon request.



HYDRAULIC SYSTEM

Three circuits. 2 variable outlet pumps for hydrostatic transmission and drum rotation. 2 gear pumps for services. Inlet and outlet filter. Heat exchanger water/oil-air type.



JOYMIX

All hydraulic functions of shovel controlled by a single - fully servo controlled Joystick.



CONCRETE MATE

Ultimate "4 sensor" electronic scale, easy to use and extra accurate for any kind of mix.



PROMIX

In-drum probe, easy allows to analyze your concrete: slump, volume, temperature and ready-mix indicator: Your on site Lab! (on request).



LOADING SHOVEL SELF ARTICULATED

Effective capacity per load 600 liters, complete with hydraulic opening gate.



CHUTE

Slewing and hydraulically tilting. Fitted with two pins easily detachable to increase the discharge height. 2 extra chutes included.



WATER SYSTEM

Self-contained. Hydraulic driven water pump, water meter, washing outlet. High pressure water pump (on request).



GRADIENT

Fully loaded 30%.



BRAKES

Oil bath disc brakes inside differential axles. Twin independent circuits. Negative hydraulic parking brake.



TYRES

Off road industrial type 16/70-20 PR 14.



STEERING

Hydrostatic. 3 ways steering. Radius: internal: mm. 1700, external mm 3.700.



ELECTRIC SYSTEM

12 Volt. 120 Ah battery for electric starter and road lighting. Safety battery cut-off.



TANKS

Water: 2x400 liters. Diesel: 115 liters. Hydraulic oil: 80 liters.



CHASSIS

Steel profile specially engineered for off-road operations.



WEIGHT

About Kg. 7.400. Equally distributed on both axles.



SAFETY

Machine equipped with checking and block valves for maximum safety of the operator. Self control avoids drum to slew if shovel's arm is lifted.



CATALOGUE

The machine is equipped with Use and Maintenance and Spare Parts Manuals according to CE regulations.

CARMIX
EVERYWHERE
YOU BUILD